



US007674973B2

(12) **United States Patent**  
**Cardas**

(10) **Patent No.:** **US 7,674,973 B2**  
(45) **Date of Patent:** **Mar. 9, 2010**

(54) **ELECTRICAL CONDUCTOR AND CABLE UTILIZING SAME**

(76) Inventor: **George Cardas**, 480 Eleventh St. SE., Bandon, OR (US) 97411

(\* ) Notice: Subject to any disclaimer, the term of this patent is extended or adjusted under 35 U.S.C. 154(b) by 0 days.

(21) Appl. No.: **12/106,133**

(22) Filed: **Apr. 18, 2008**

(65) **Prior Publication Data**

US 2009/0260849 A1 Oct. 22, 2009

(51) **Int. Cl.**  
**H01B 7/00** (2006.01)

(52) **U.S. Cl.** ..... **174/36**; 174/102 R; 174/108

(58) **Field of Classification Search** ..... 174/102 R, 174/105 R, 107, 108

See application file for complete search history.

(56) **References Cited**

U.S. PATENT DOCUMENTS

2,769,149 A 10/1956 Kreer, Jr.

4,628,151 A	12/1986	Cardas	.....	174/114
4,701,730 A	10/1987	Okamoto		
4,980,517 A	12/1990	Cardas	.....	174/127
4,997,992 A	3/1991	Low		
5,929,374 A *	7/1999	Garland	.....	174/28
7,329,814 B2 *	2/2008	Hacker	.....	174/110 R

\* cited by examiner

*Primary Examiner*—William H Mayo, III  
(74) *Attorney, Agent, or Firm*—Dorsey & Whitney LLP

(57) **ABSTRACT**

A conductor includes a central element having a length, a plurality of insulated strands disposed about the central element in at least first and second concentric layers, a layer of a dielectric material having a velocity of propagation disposed around the plurality of insulated strands. Each of the plurality of insulated strands has a conductive element and a layer of insulative material disposed around the conductive element and a length approximately equal to an inverse of the velocity of propagation of associated dielectric materials multiplied by the product of the length of the central element and the number one hundred.

**21 Claims, 6 Drawing Sheets**

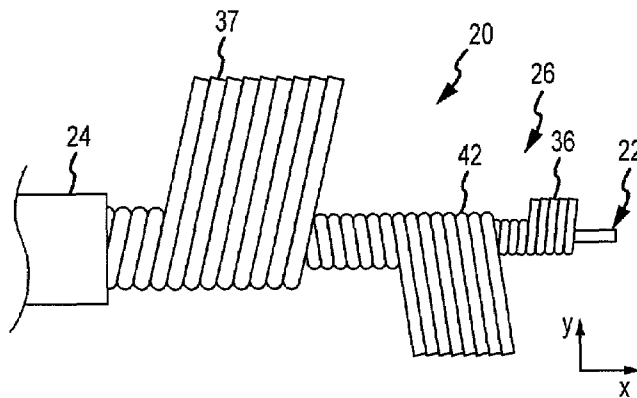
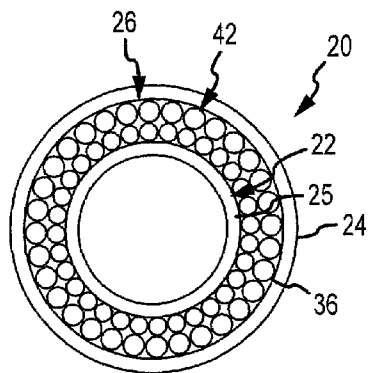

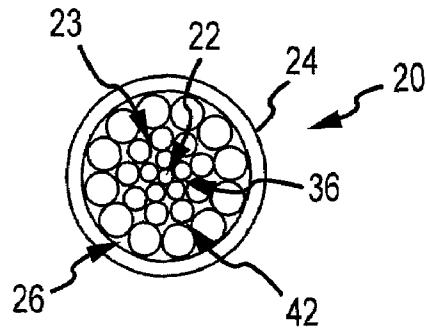

FIGURE 1

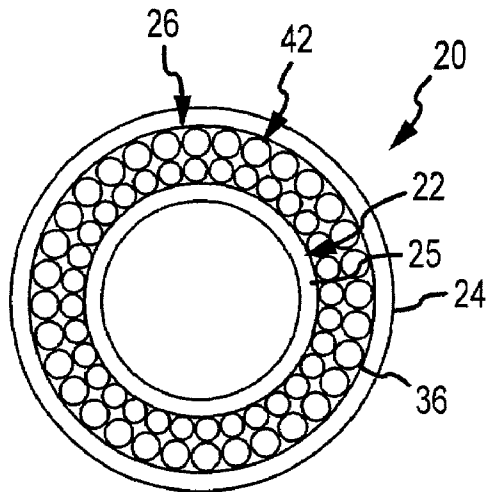

FIGURE 2

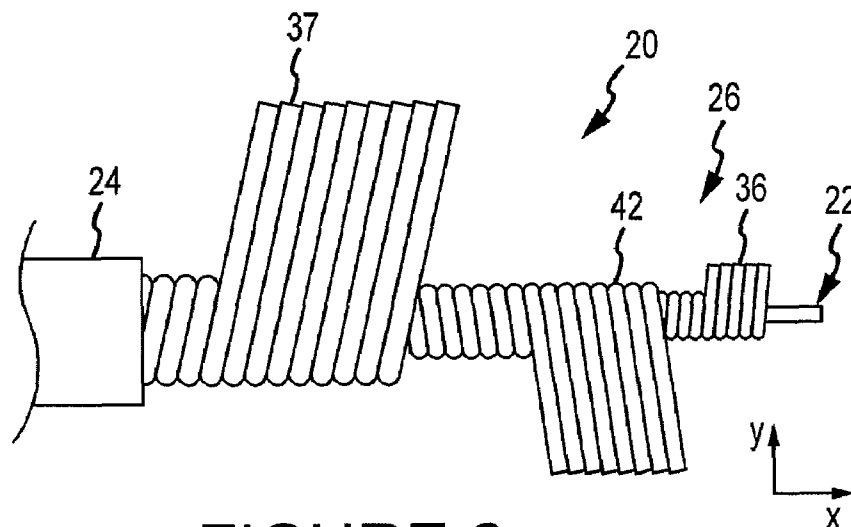

FIGURE 3

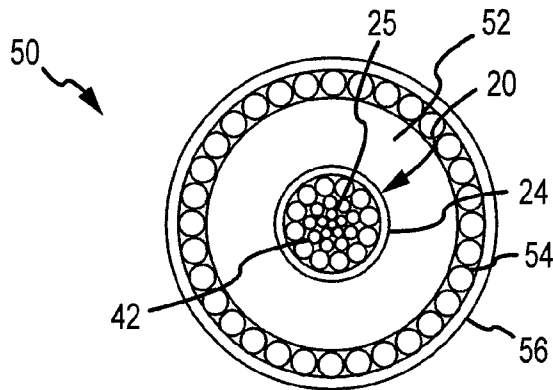

FIGURE 4

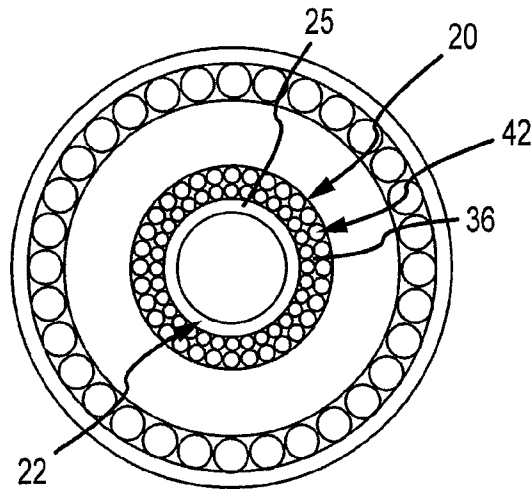

FIGURE 5

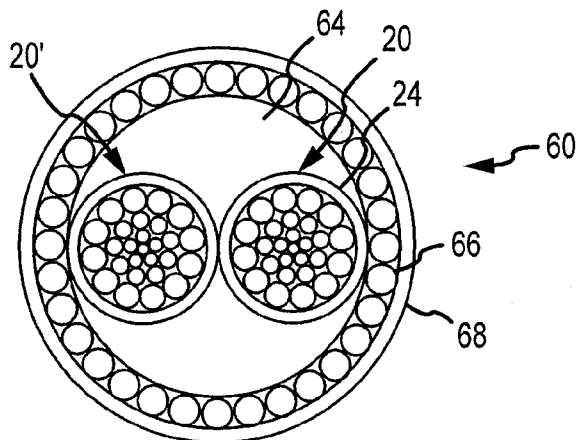

FIGURE 6

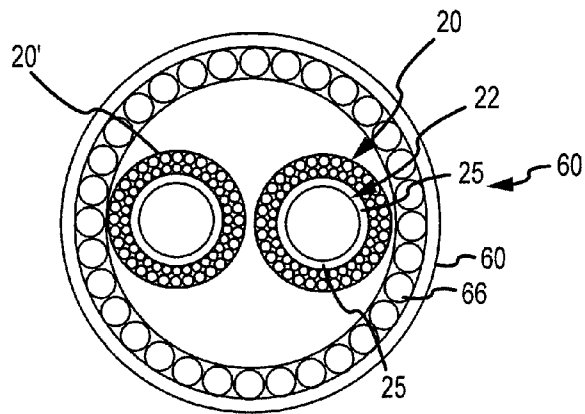

FIGURE 7

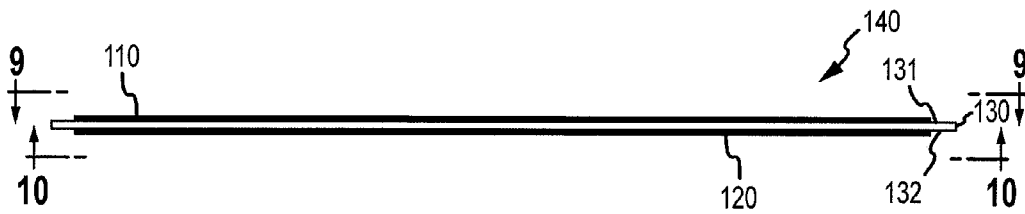
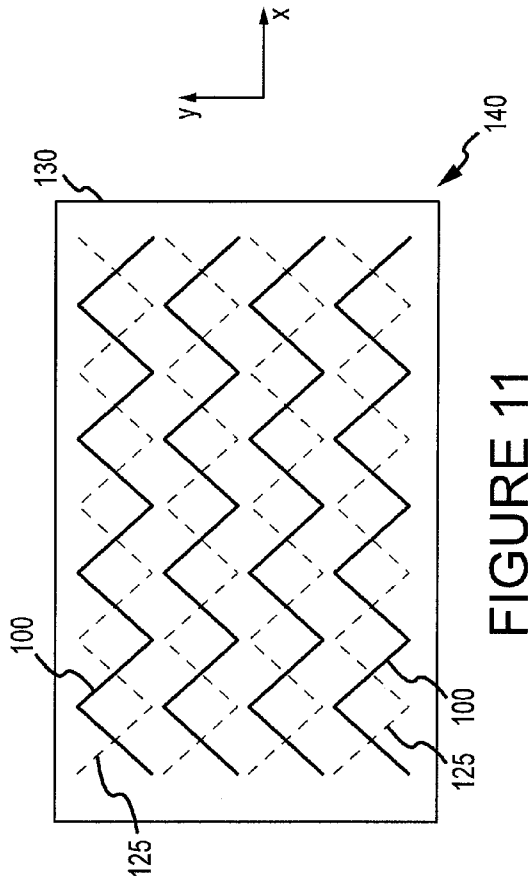
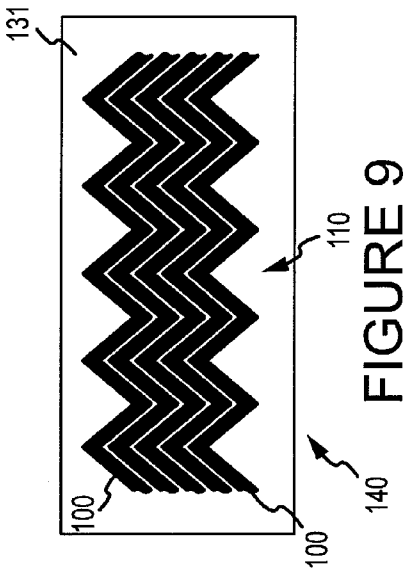
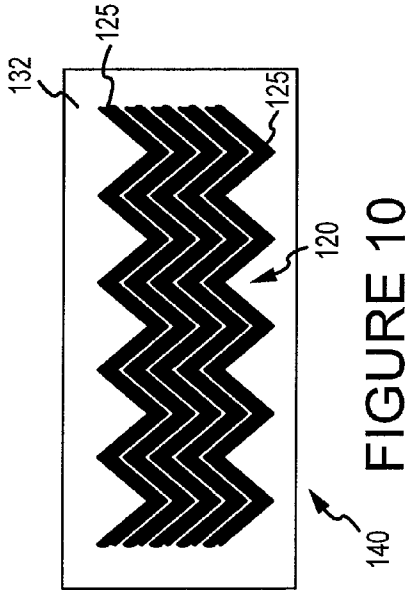

FIGURE 8



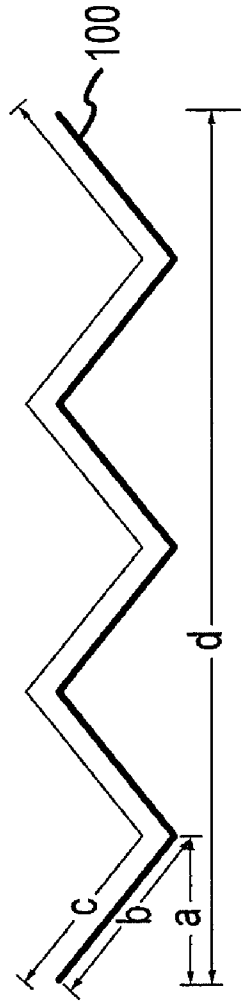

FIGURE 12

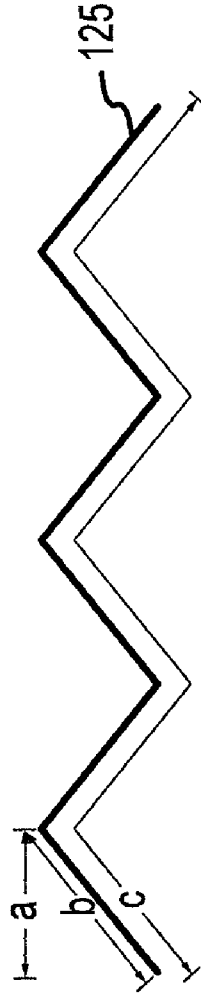

FIGURE 13

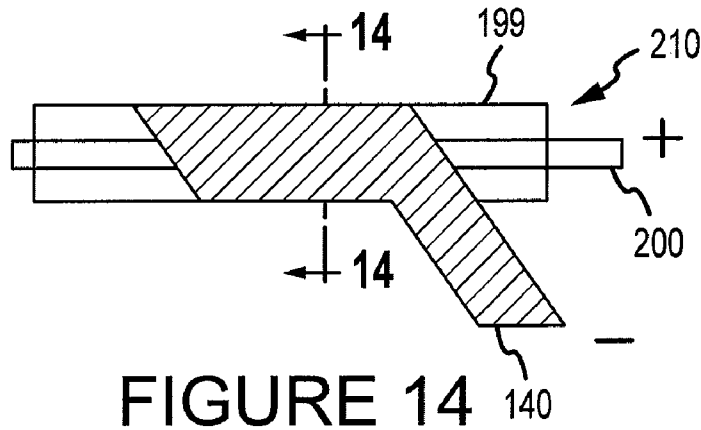

FIGURE 14

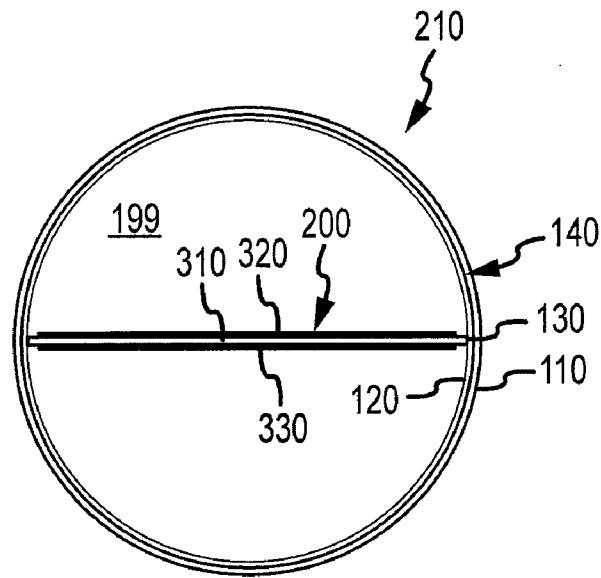

FIGURE 15

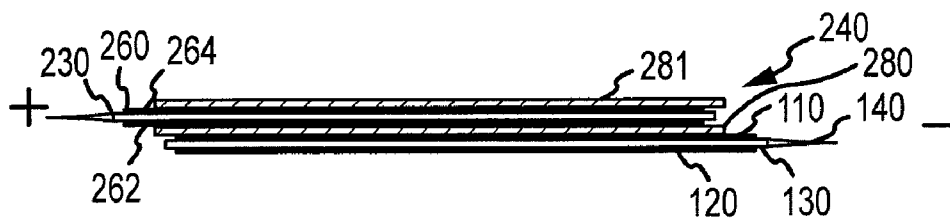

FIGURE 16

## ELECTRICAL CONDUCTOR AND CABLE UTILIZING SAME

### FIELD

The present invention relates to electrical conductors and more particularly to electrical conductors with multiple conductive strands.

### BACKGROUND

Generally, an electric cable may hold a charge in many ways. For example, a charge may be held in an empty space or air between conductor tracks. Another way a charge may be held is in dielectric polarizations or mechanical stresses. At low frequencies charges often scatter towards a steady state in a statistically randomized event like white noise due to polarization mechanisms that move and orientate dielectric structures. The impact of this noise may be exaggerated by the sequential decay in a cable's dielectric and fueled by the conductor/dielectric transition time differential. This effect causes dielectric constants to drop with frequency, adding noise and jitter to a transmitted signal.

Signal propagation in a cable is generally governed by an interaction between one or more conductors and an insulating dielectric material. The signal propagating on the conductor needs to charge the surrounding dielectric material. Problems can arise when an electromagnetic wave propagates at different velocities in a conductor and an adjacent dielectric. As energy is stored and transferred at different time constants in conductors and dielectrics, a complex kinetic resonator can result, impeding performance of the cable.

In the early development of cable technology, load coils were placed in series with cable conductors at intervals along the length of the conductor. These load coils slowed the conductor to better match propagation in the dielectric. However, the load coils were bulky and caused the cable to lose dynamic range, bandwidth, and signal intensity. In particular, the load coils severely limited high frequency signal transmission because they acted as inductors and choked the line.

What is needed, therefore, is an electrical cable with a conductor having evenly distributed inductance and propagation delay, to match its wave propagation velocity to the dielectric materials in the cable.

### SUMMARY

In general, embodiments of the present invention provide conductors. One embodiment of a conductor includes a central element having a length, a plurality of insulated strands disposed about the central element in at least first and second concentric layers, and a layer of a dielectric material having a velocity of propagation disposed around the plurality of insulated strands. Each of the plurality of insulated strands has a conductive element and a layer of insulating material disposed around the conductive element and a length approximately equal to an inverse of the velocity of propagation of an electromagnetic field in the dielectric material multiplied by the product of the length of the central element and the number one hundred.

As will be realized by those of ordinary skill in the art upon reading the entirety of this disclosure, the invention is capable of modifications in various aspects, all without departing from the spirit and scope of the present invention. Accordingly, the drawings and detailed description are to be regarded as illustrative in nature and not restrictive.

## BRIEF DESCRIPTION OF THE DRAWINGS

The accompanying drawings, which are somewhat schematic in many instances and are incorporated in and form a part of this specification, illustrate several embodiments of the invention and, together with the description, serve to explain the principles of the invention.

FIG. 1 is a cross-sectional view of an exemplary conductor.

FIG. 2 is a cross-sectional view of an additional embodiment of an exemplary conductor.

FIG. 3 is a side view of the exemplary conductor in FIG. 1 with a dielectric material partially removed for ease of illustration and a plurality of strands in a partially unwound state for ease of illustration.

FIG. 4 is a cross-sectional view of an exemplary co-axial cable having the conductor in FIG. 1.

FIG. 5 is a cross-sectional view of an exemplary co-axial cable having the conductor in FIG. 2.

FIG. 6 is a cross-sectional view of an exemplary multi-axial cable having at least two conductors with each having a conducting central member.

FIG. 7 is a cross-sectional view of an exemplary multi-axial cable having at least two conductors with each having a non-conducting central member.

FIG. 8 is a cross-sectional view of an embodiment of a flat conductor having a two patterned conductive layers on either side of a non-conductive film.

FIG. 9 is a plan view of the conductor of FIG. 8 along the line 9-9.

FIG. 10 is a plan view of the conductor of FIG. 8 along the line 10-10.

FIG. 11 is a schematic plan view, similar to FIG. 9, of the conductor of FIG. 8.

FIG. 12 is a plan view of one of the patterned conductive strands in a patterned conductive layer of the conductor of FIG. 8.

FIG. 13 is a plan view of one of the patterned conductive strands in a patterned conductive layer of the conductor of FIG. 8.

FIG. 14 is a side view of a coaxial cable utilizing the conductor of FIG. 8 as a negative or shield electrode.

FIG. 15 is a cross-sectional view of the cable of FIG. 13 according to an embodiment of the present invention.

FIG. 16 is a side view of a capacitor employing the conductor of FIG. 8 as a negative electrode and a second conductor according to an embodiment of the present invention as a positive electrode.

## DETAILED DESCRIPTION OF VARIOUS EMBODIMENTS

In general, an exemplary conductor is provided. The conductor is capable of being used in a multiple-strand cable. The conductor may be used in many applications including electrical power transmission lines, electrical signal transmission lines, and audio signal cables or speaker cables.

Embodiments of conductors described herein are designed to more closely match a velocity of signal propagation along the conductor to the velocity of signal propagation in an adjacent dielectric. The conductor includes a plurality of conductive strands, where the strand lengths are selected such that a ratio of the strand length to conductor length is proportional to an inverse of the velocity of propagation in the adjacent dielectric. Embodiments of conductors described have generally uniform construction along their length. That is, the conductor's impedance is relatively constant per unit length of conductor. This is unlike load coils placed at discrete

intervals where the impedance of the cable is much higher at the load coil than the remainder of the cable. The conductive strand length is increased relative to the conductor length in some embodiments by winding one or more strands around a central element a certain number of turns per unit length sufficient to arrive at the desired length, based on the velocity of propagation in the dielectric and circumference of the strand layer. In other embodiments, the increased strand length is achieved by etching a conductive material in an angled pattern such that the desired strand length is achieved per unit length of conductor. Generally, the strand length is chosen relative to the conductor length such that a velocity of propagation in the strand, measured along the conductor's length will approximately equal the velocity of propagation in an adjacent dielectric. By matching a velocity of propagation along a conductor with the velocity of propagation in an adjacent, dielectric, embodiments of conductors according to the present invention may reduce or substantially eliminate certain resonance effects in the conductor/dielectric system. Embodiments of a conductor according to the present invention may include a plurality of strands of a conductive material. The plurality of strands may include at least two concentric layers of strands disposed around a central element. The central element may be a conducting material or a non-conducting material. Surrounding the plurality of strands is a layer of a dielectric material in which an electromagnetic signal has a certain, limited, velocity of propagation. The central element has a length and the strands in at least two concentric layers each have a length approximately equal to an inverse of the velocity of propagation multiplied by the product of the length of the central element and the number one hundred. As will be described below, although the concentric layers have different cross-sectional areas, the conductive strand length is approximately the same in each layer.

A conductor **20**, as shown in FIG. 1, is provided. The conductor **20** may include a central member **22**, a dielectric material **24**, and a plurality of strands **26** disposed between the dielectric material **24** and the central member **22**. The central member **22** has a length and a diameter or other transverse dimension. The central member **22** may include a conductive material **23**. The conductive material of the central member **22** may be formed from a strand made of copper, aluminum or both. Additionally, the central member **22** may include either a bare wire or a non-conductive strand. Whether the central member **22** is insulated or not may depend on, among other things, the application in which the conductor is used. For example, electrical power transmission lines may be formed from aluminum requiring the central member **22** to be made of steel for strength. On the other hand electrical signal transmission lines, audio or data cables may be formed from copper or silver and require a bare or non conductive strand.

Alternatively, the central member **22** may include a non-conductive member **25** having a diameter as shown in FIG. 2. More specifically, the central member **22** may include a tube-like member. The central member **22** may be made of a dielectric material.

Each of the plurality of strands **26** are conductive strands and would have a thin insulative coating (e.g. Magnet wire) (not shown in FIG. 1). The plurality of strands **26** may include a first concentric layer **36** of strands disposed adjacent and around the central member **22** as shown in FIGS. 1-3. The first concentric layer **36** may include a diameter and a length. The strands of the first concentric layer **36** may have the same diameter. The strand diameter of the first concentric layer **36** may be equal to the diameter of the central member **22**. In one embodiment, if the central member **22** is a conducting mem-

ber **23**, the strands of the first concentric layer **36** may be larger in diameter than the diameter the central member **22** as shown in FIG. 1. The strands of the first concentric layer **36** are in close proximity to or contact one another circumferentially. In another embodiment, if the central member **22** is a non-conducting member **25**, the diameter of the central member **22** may be larger than the diameter of individual strands of the first concentric layer **36** as shown in FIG. 2.

The plurality of strands **26** may also include a second concentric layer **42** of strands disposed around the first concentric layer **36** of strands and the central element **22**. In other words, as shown in FIGS. 1-3, the strands of the first or inner layer **36** of strands contact the central member **22** and the strands in the second or outer layer **42** of strands contact the inner layer **36** of strands. The first concentric layer **36** of strands may be wound helically around the central element **22**, while the second concentric layer **42** is wound counter-helically around the central element **22** and the first concentric layer **36**. A third concentric **37** may then be wound helically around the central element **22**. Subsequent concentric layers, if any, similarly alternate the helical- and counter-helical rotation around the central element **22**. By providing concentric layers of strands wound around the central element **22** in opposite directions, components of signal propagation not along the direction of the central element **22** will be summed and slowed from the perspective of surrounding dielectric material. So for example, an electromagnetic signal may be applied to the conductor **20** for propagation in the positive x direction shown in FIG. 3. As the signal propagates along the first layer **36** of strands, it may create an electromagnetic field in the positive y axis direction, indicated in FIG. 3 as well as the positive x direction. Recall desired signal propagation direction is along the positive x axis direction shown in FIG. 3. The summed electromagnetic field of the x and y axis windings will progress along the center line of the conductor at a rate reduced in proportion to the accumulated strand length determined by the formula.

Each strand of the second concentric layer **42** includes a diameter or other transverse dimension and a length. The strands of the first concentric layer **36** may have the same diameter. The strand diameter of the second concentric layer **42** of strands may be equal to the strand diameter of the first concentric layer **36** of strands. Otherwise, the strand diameter of the second concentric layer **42** of strands may be larger than the strand diameter of the first concentric layer **36** of strands. The length of the strands in the second concentric layer **42** is approximately equal to the length of the strands in the first concentric layer **36**. The strands in the plurality of layers **26** may be individually insulated depending on the application as discussed above.

The conductor **20** may have any number of additional layers of strands of progressively increasing in cross-sections. In the conductor **20**, the cross-sectional dimension of the strands increases progressively toward the outer circumference, whereby the above-discussed advantages are achieved. The strand layers **36**, **42** may be utilized with or without a preferred strand sizing according to which the strand cross-sections are relatively sized to conform as closely as possible to the golden ratio progression of 1 to approximately 1.618. That is, the cross-sectional area of each strand in a next layer may be approximately 1.618 times the cross-sectional area of strands in a previous layer. The golden ratio progression may be of the kind disclosed in U.S. Pat. No. 4,980,517, titled "Multi-Strand Electrical Cable," and hereby incorporated by reference in its entirety for any purpose.

A layer of dielectric material **24** encases the plurality of strands **26** shown in FIGS. 1-3. The dielectric material **24** may

5

be any material that is a poor conductor of electricity. The dielectric material may include rubber, cotton, Teflon, paper, pvc or other materials suitable for this function. Electromagnetic fields have a velocity of propagation (VoP) in the dielectric material **24**. The VoP is a parameter that characterizes the speed to which the signal propagation is limited in the dielectric material. The VoP of the dielectric material **24** depends on a dielectric constant of the dielectric material **24**. More specifically, the VoP is proportional to an inverse of the square root of the dielectric constant of the dielectric material **24** as shown in the following equation:

$$\text{VoP} = 100 / \sqrt{\text{DC}} \tag{Equation 1}$$

wherein DC is the dielectric constant. Equation 1 expresses VoP as a percentage of the speed of light. For example, for TFE, the dielectric constant is 2, and the velocity of propagation calculated according to Equation 1 is therefore 70.71%, indicating that an electromagnetic wave will propagate in the TFE at 70.71% of the speed of light. Dielectrics with a high air content may have a VoP of approximately 82%. For some foam dielectrics, the VoP may approach around 90%. For conductive materials, the VoP is generally assumed to be 100%. Embodiments of the present invention provide conductors with conductive strands having a longer effective length than the length of the conductor, effectively slowing the VoP in the conductive strands as measured along the length of the conductor to be closer to the VoP in the associated dielectric material.

The VoP is used to determine the lengths of the first and second concentric layers **36**, **42** of strands. As stated above, the length of the first concentric layer **36** of strands is approximately equal to the length of the second concentric layer **42** of strands. These lengths may be expressed by the following formula:

$$L_{L1} = L_{L2} \approx (1/\text{VoP}) * 100 * L_{CM} \tag{Equation 2}$$

wherein  $L_{L1}$  is the length of the first concentric layer **36** of strands,  $L_{L2}$  is the length of the second concentric layer **42** of strands, VoP is the velocity of propagation of the dielectric material **24**, and  $L_{CM}$  is the length of the central member **22**. This is also generally the length of the conductor **20**.

Strands in the first concentric layer **36** are wound around the central member **22** a number of turns per inch (TPI) along its length. The number of TPI per layer is chosen such that the length of strands in each layer is approximately equal, and the length of the strands is distributed evenly across the length of the conductor. The number of TPI may be calculated as follows:

$$L_{CM} + (\text{Mean } C \times \text{TPI}) = (L_{L1} - L_{CM}) / \text{Mean } C \tag{Equation 3}$$

In substituting equation 1 into equation 2 for  $L_{L1}$ , we obtain

$$\text{TPI} = [(1/\text{VoP}) * 100 * L_{CM} - L_{CM}] / \text{Mean } C \tag{Equation 4}$$

wherein TPI is the turns per square inch,  $L_{L1}$  is the length of the first concentric layer **36** of strands,  $L_{CM}$  is the length of the central member **22**, and Mean C is the mean circumference of the first concentric layer **36** of strands.

The mean circumference may be defined as follows:

$$\text{Mean } C = (C_{L1} + C_{CM}) / 2 \tag{Equation 5}$$

wherein Mean C is the average circumference between the first strand layer **36** and the conductor **20**,  $C_{L1}$  is the circumference of the first concentric layer **36**, and  $C_{CM}$  is the circumference of the central member **22**.

6

Strands in the second concentric layer **42** are wound a different number of TPI around the first layer **36**, as shown in FIG. **3**. The number of TPI for the second layer is chosen based on the diameter of the strands and layers such that the length of strands in the second layer is approximately equal to the length of strands in the first layer. The number of TPI for the second concentric layer **42** of strands may be calculated as follows:

$$\text{TPI} \approx L_{L2} - L_{CM} / \text{Mean } C \tag{Equation 6}$$

wherein TPI is the turns per square inch,  $L_{L2}$  is the length of the second concentric layer **42** of strands,  $L_{CM}$  is the length of the central member of strands, and Mean C is the mean circumference of the second concentric layer of strands. The TPI for the second concentric layer **42** of strands is less than the TPI for the first concentric layer **36** of strands.

The mean circumference of the second concentric layer of strands be defined as follows:

$$\text{Mean } C = (C_{L2} + C_{L1}) / 2 \tag{Equation 7}$$

wherein Mean C is the average circumference between the first concentric layer **36** of strands and the second concentric layer **42** of strands,  $C_{L2}$  is the circumference of the second concentric layer **42** of strands, and  $C_{L1}$  is the circumference of the first concentric layer **36** of strands.

The following chart provides exemplary values for a conductor, as shown in FIG. **1**, having four layers of strands encircling a central strand. For the example below, the dielectric material is Teflon, which has a velocity of propagation of 70%, the central strand has a length equal to 1 inch, and Equation 4 defines TPI. In the following chart, 'L' indicates the layer number, 'OD' refers to an outside diameter of the layer, 'Mean C' refers to the mean circumference of the layer, 'TPI' refers to a number of twists per inch; 'AWG' refers to the approximate wire gauge of the layer considered as a whole, a measure proportional to the cross-sectional diameter or cross-sectional area of the layer, 'CMA' refers to the circular mil area, the cross-sectional area of each strand in the layer, and 'SD' refers to the number of strands x the gauge of each strand in the layer. As can be seen in the table below, to keep the length of strands in each layer constant, the turns per inch decreases as the layer outer diameter increases. The turns per inch and outer diameters in the table below are chosen such that the resultant length of strands, approximately equal in each layer, will slow the propagation of electric fields along the conductor to better match velocity of propagation in teflon.

Strand Chart for a Teflon Example

L	OD	MEAN C	TPI	AWG	CMA	SD
0	.003	0	0	40	9.61	1 x 40
1	.011	.022	18.2	30.5	80	5 x 38
2	.021	.050	8	25	225	9 x 36
3	.034	.087	4.63	21	516	13 x 24
4	.050	.113	3	17.5	1024	16 x 32

In one embodiment, the conductor **20** may be included in a co-axial cable **50**, as shown in FIG. **4**. The conductor may have the conducting central member **23**. The co-axial cable **50** includes the conductor **20**, an insulation member **52** surrounding the conductor **20**, a ground layer of strands **54** enclosing the insulation member **52**, and an outer insulation member **56** surrounding the ground layer **54**. In an alternative

embodiment, the conductor **20** having the non-conducting central member **25** as shown in FIG. 5.

In another embodiment, the conductor **20** may be used in a multi-axial cable **60**, such as a twin-axial cable as shown in FIG. 6, having at least two conductors. The conductors **20** may each include the conducting central member **23**. In an embodiment related to a twin-axial cable, the multi-axial cable **60** may include the conductor **20**, a second conductor **20'**, an insulation member **64**, a ground layer of strands **66**, and an outer insulation member **68** surrounds the ground conductor **66**. As shown in FIG. 7, the multi-axial cable **60** may alternatively include the conductors **20** each having the non-conducting member **25**.

Further embodiments of the present invention provide conductors that may be flat, where length in the conductive strands is achieved by patterning a conductive layer on a substrate. The conductive layer is patterned so that each conductive strand has a length such that propagation in the conductive strands along the conductor approximately equals a propagation velocity in an associated dielectric material. FIG. 8 depicts an embodiment of a conductor **140** constructed in this manner. A sheet **130** of non-conductive material, such as mylar or polypropylene, has opposite first and second sides **131** and **132**. The sheet may have a width ranging from 0.4 to 6 mil and preferably ranging from 1 to 3 mil. Patterned conductive layers **110** and **120**, each having a width ranging from 0.0004 mil to 6 mil depending on application are formed on the first and second sides **131** and **132**, respectively. The patterned conductive layers **110** and **120** each include a plurality of individual conductive strands of equal length formed of a conductive material.

Patterned conductive layers **110** and **120** are shown in FIGS. 9 and 10, respectively. FIG. 9 is a plan view of the conductor **140** of FIG. 8 taken along the line 9-9. FIG. 10 is a plan view of the conductor **140** of FIG. 8 taken along the line 10-10. Patterned conductive layer **110** includes a plurality of strands **100** of conductive material, several of which are identified in FIG. 9. The strands **100** are patterned to increase their length and improve matching between the velocity of propagation in the conductive strands **100** and an associated dielectric material with which the conductor **140** may be used. Similarly, patterned conductive layer **120** includes a plurality of conductive strands **125**, angled to improve matching between the velocity of propagation in the conductive strands **125** and a dielectric material with which the conductor **140** may be used.

The conductive strands **100** and **125** may be patterned through any known methods, including etching or other material removal techniques. Alternatively, in some embodiments, patterned conductive strands **100** and **125** are deposited in a pattern on the dielectric material **130**. Conductive strands **100** and **125** may be oriented in opposite directions on opposite sides of the dielectric material **130** as shown in FIGS. 9 and 10 and shown schematically in FIG. 10A. FIG. 10A depicts a top-down plan view of the conductor **140**. The strands **100** and **125** are shown schematically as lines and further separated for ease of illustration. Strands **125** are disposed on an opposite side of the non-conductive material **130** as the strands **100**, as shown in FIG. 8, and in FIG. 10A the strands **125** on the opposite side of the non-conductive material **130** are shown as dashed lines. As shown in FIG. 10A, the strands **125** and **100** form a criss-cross pattern. The mirror imaged strand layers sum their respective fields to a common vector. The resultant summed field is slowed to better match velocity of propagation in an associated dielectric.

The conductive strands **100** and **125** are patterned to increase their length relative to the length of the conductor **140**. One of the plurality of strands **100** is shown in FIG. 11, and one of the plurality of strands **125** is shown in FIG. 12. Each of the illustrated strands **100** and **125** is patterned in a

zig-zag such that the ratio of length  $b$  to length  $a$  is selected proportional to an inverse of the velocity of propagation in an associated dielectric material. Accordingly, the ratio of length  $c$  of the entire strand **100** or **125**, respectively, to the length  $d$  of the conductor itself, is also proportional to the inverse of the velocity of propagation in an associated dielectric. In one embodiment, an angle of the conductive strands to a direction of propagation is about 52 degrees for matching with a dielectric such as teflon or polypropylene. Geometries other than a straight zig-zag, such as curved or other shapes, may be used in other embodiments.

Embodiments of the flat conductors described with reference to FIGS. 8-10A may be utilized to form cables, capacitors, or other devices having an associated dielectric. Recall the length of strands **100** and **125** in the conductor is chosen based on the velocity of propagation in the associated dielectric. One embodiment of the conductor **140** in use with an associated dielectric is shown in FIG. 13 depicting the use of the conductor **140** in a coaxial cable. The conductor **140** is wrapped around a dielectric material **199** that itself encases a central conductor **200** to form a coaxial cable **210**. The conductor **200** may be similar to the conductor **140** in some embodiments, as is shown generally in FIG. 14, showing a cross-sectional view of the cable **210** of FIG. 13 along the line 14-14. The cable **210** includes the conductor **140** including patterned conductive layers **110** and **120** wrapped around the central dielectric material **199** and a second conductor, such as conductor **200**, having a similar structure as the conductor **140**. The conductor **200** includes, for example, non-conductive material layer **310** and conductive strands in two layers, **320** and **330**.

Embodiments of conductors according to the present invention may further be used as one or more electrodes in a capacitor, as shown in FIG. 15 where conductors **140** and **230** form two electrodes of capacitor **240**. The conductor **140**, including a central non-conductive layer **130** and two patterned conductive layers **110** and **120**, as shown in FIGS. 8-10, serves as a first negative electrode of the capacitor **240** in FIG. 15. A second conductor **230**, substantially similar to conductor **140**, also includes a central non-conductive material **260** having a first patterned conductive layer **262** on a first side of the central non-conductive material **260** and a second patterned conductive layer **264** on a second side of the central non-conductive material. As with the conductor **140**, the patterned conductive layers **262** and **264** of the conductor **230** each include a plurality of conductive strands, for example like strands **100** and **125** described above, patterned such that a velocity of propagation in the conductive strands along a length of the conductor is approximately equal to a velocity of propagation in an associated dielectric material. The capacitor **240** is formed by placing a capacitor dielectric **280** between the first conductor **140** and the second conductor **230**. The capacitor dielectric **280** is the associated dielectric material and velocity of propagation in the capacitor dielectric **280** will in part dictate the length of the conductive strands in the conductors **140** and **230**. The length of the strands in the conductive layers **110**, **120**, **262** and **264** are chosen based on the velocity of propagation in the capacitor dielectric **280**. A further layer of capacitor dielectric **281** may be provided such that the capacitor structure shown in FIG. 15 may be rolled up to form a completed capacitor structure.

Accordingly, one aspect of embodiments of the invention provides a constant and low inductance along a conductor. Lengths of conductive strands in the conductor are selected such that a wave propagation velocity along a length of the conductor approximately equal to the velocity of propagation in an associated dielectric. This is achieved by designing the conductor such that all conductive strand lengths are proportioned to the inverse of the dielectric's velocity of propagation. In one embodiment, the length is determined in part by

a number of turns per unit length, whereby the number of turns on the layers is decreased as they reach the surface of the conductor to keep strand length approximately the same in each layer. This allows the impedance and wave propagation velocity of the conductor to be matched continuously rather than at intervals, thereby diminishing transmission losses, reducing resonance effects and persevering bandwidth.

Furthermore, in some embodiments of cables incorporating conductors according to embodiments of the present invention, a net velocity of propagation of the cable at length may be approximately equal to that of a conventionally stranded cable (that of the dielectric). However, at cable lengths shorter than a wavelength of the signal the impedance may be substantially more constant. Loss, signal distortion, noise and jitter may be reduced.

From the foregoing it will be appreciated that, although specific embodiments of the invention have been described herein for purposes of illustration, various modifications may be made without deviating from the spirit and scope of the invention.

The invention claimed is:

1. A conductor comprising a central element having a length, a plurality of insulated strands disposed about the central element in at least first and second concentric layers, a layer of a dielectric material having a velocity of propagation disposed around the plurality of insulated strands, each of the plurality of insulated strands having a conductive element and a layer of insulative material disposed around the conductive element and a length selected such that a velocity of propagation of an electromagnetic wave in the conductive element along the length of the central element is approximately equal to the velocity of propagation in the dielectric material.

2. The conductor of claim 1, wherein the length of each of the plurality of insulated strands is approximately equal to an inverse of the velocity of propagation of the dielectric material multiplied by the product of the length of the central element and the number one hundred.

3. The conductor of claim 1, wherein the central element includes a conductive central strand.

4. The conductor of claim 1, wherein the central element is made of a nonconductive material.

5. The conductor of claim 1, wherein the first and second concentric layers include an outer layer of strands and an intermediate layer of strands.

6. The conductor of claim 5, wherein the intermediate layer of strands has a first number of turns per inch and the outer layer of strands has a second number of turns per inch that is different from the first number of turns per inch.

7. The conductor of claim 6, wherein the intermediate layer of strands has a length and a mean circumference and wherein the first number of turns per inch is approximately equal to the difference between the length of the intermediate layer of strands minus the length of the central element divided by the mean circumference of the intermediate layer of strands.

8. The conductor of claim 6, wherein the outer layer of strands has a length and a mean circumference and wherein the second number of turns per inch is approximately equal to the difference between the length of the outer layer of strands minus the length of the central element divided by the mean circumference of the outer layer of strands.

9. The conductor of claim 6, wherein the second number of turns per inch of the outer layer of strands is less than the first number of turns per inch of the intermediate layer of strands.

10. The conductor of claim 5, wherein the central element has a diameter and each strand in the intermediate layer of strands has a diameter greater than the diameter of the central element.

11. The conductor of claim 10, wherein the diameters of the strands in the intermediate layer are substantially constant.

12. The conductor of claim 5, wherein each strand in the intermediate layer of strands has a diameter and each strand in the outer layer of strands has a diameter different than the diameter of each strand in the intermediate layer.

13. A conductor for use with an associated dielectric material having a velocity of propagation, the conductor comprising a nonconductive film having a length and a first side and a second side, a first conductive layer on the first side including a plurality of conductive strands each patterned such that a length of the conductive strands is greater than the length of the nonconductive film, the conductive strand length being proportional to an inverse of the velocity of propagation in the dielectric material.

14. The conductor of claim 13, wherein the plurality of conductive strands in the first conductive layer each have a first pattern including an angle of approximately 52 degrees with respect to a direction of propagation along the conductor.

15. The conductor of claim 13, wherein the nonconductive film is polypropylene.

16. The conductor of claim 14, further comprising a second conductive layer on the second side, the second conductive layer including a second plurality of conductive strands having a length equal to the length of the first plurality of conductive strands, the second plurality of conductive strands having a second pattern opposing the first pattern.

17. A cable comprising a conductive member, a central element having a length, a plurality of insulated strands disposed about the central element in at least first and second concentric layers, a dielectric material having a velocity of propagation disposed between the conductive member and the plurality of insulated strands, each of the plurality of insulated strands having a conductive element and a layer of insulative material disposed around the conductive element and a length approximately equal to an inverse of the velocity of propagation multiplied by the product of the length of the central element and the number one hundred.

18. The cable of claim 17, wherein the conductive member is an additional central element and an additional layer of strands disposed around the additional central element.

19. The cable of claim 17, wherein the conductive member is a conductive shield extending around the dielectric material and the plurality of insulated strands.

20. The cable of claim 17 further comprising a coaxial member and a sheath enclosing the layer of dielectric material and the coaxial member.

21. The cable of claim 20, wherein the coaxial member includes an additional central element having a length, an additional plurality of insulated strands disposed about the central element in at least first and second additional concentric layers, an additional layer of a dielectric material having a velocity of propagation disposed around the additional plurality of insulated strands, each of the additional plurality of insulated strands having an additional conductive element and an additional layer of insulative material disposed around the additional conductive element and a length approximately equal to an inverse of the velocity of propagation of the additional layer of the dielectric material multiplied by the product of the length of the additional central element and the number one hundred.